

MOVO

Mod. MOVO Ø35

Mod. MOVO Ø45



MOTORI TUBOLARI

IT

TUBULAR MOTORS

EN

ROHRMOTOREN

DE

MOTEURS TUBULAIRES

FR

MOTORES TUBULARES

ES



ISTRUZIONI - INSTRUCTIONS - EINSTELLANLEITUNGEN
INSTRUCTIONS - INSTRUCCIONES

ELECTRICAL CONNECTIONS

- To prevent any danger or malfunction, the size of electrical control components connected to the motor must be compatible with the electrical features of the motor.
- Means for disconnection must be incorporated in the fixed wiring in accordance with the national installation standards.
- The selectors inverting the direction of rotation of the motor must be provided with mechanical interlocking.
- Invert the brown and the black conductor to change the direction of rotation.
- **NEVER** connect two or more motors to the same selector (parallel connection). If you couple two motors, use multi-poles selectors only.
- **NEVER** connect two or more selectors to the same motor.
- For outdoor use, provide the appliance with a supply cable with designation H05RN-F containing at least 2% of carbon.

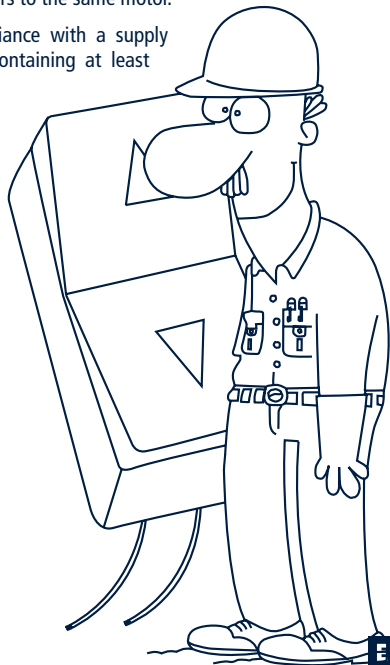
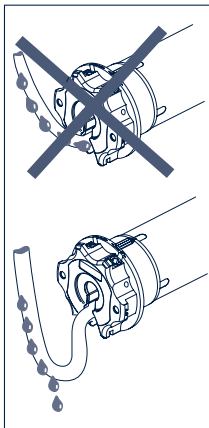

230 V 50 Hz

- 1- brown
- 2- black
- 3- blue
- 4- yellow-green

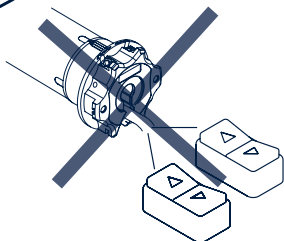
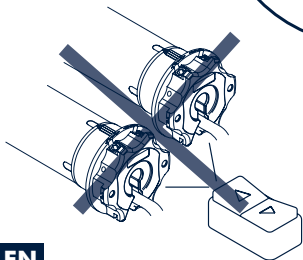
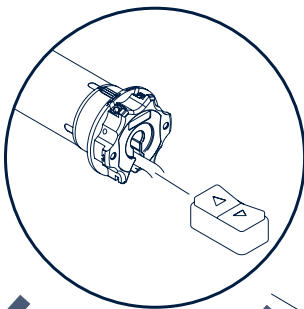
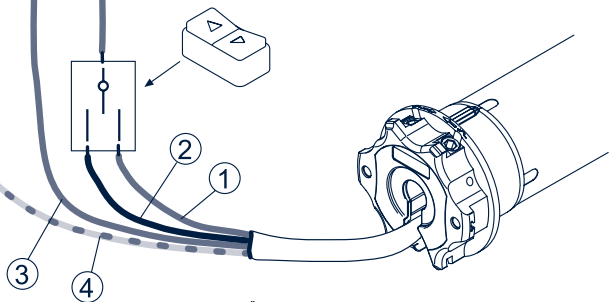

HOW TO PREPARE THE MOTOR

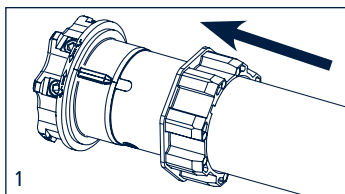
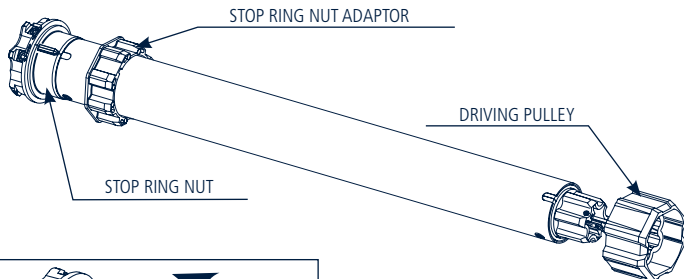

1. Insert the adaptor in the stop ring nut mating the groove with the reference notch and push till they touch.

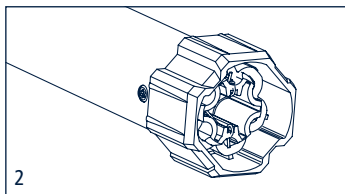

2. Fix the driving pulley on the motor pin until the stop pin clicks.

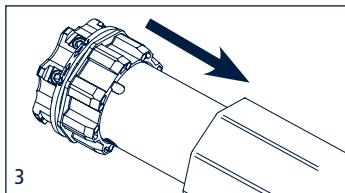

3. Insert the motor fully in the rolling tube.

NB: If you use tubes with a round form, the driving pulley must be fixed to the tube, and the installation is to be paid by the person who installs the system. For other tube sections the fitting is optional, but strongly recommended.

ADJUSTEMENT OF THE LIMIT SWITCHES

These tubular motors are provided with a system of electromechanical limit switches that stops the feed when the awning or the rolling shutter get to the maximum opening or closing limits. To adjust these limits and adapt them to any need, simply screw or unscrew the two adjusting screws on the motor head. The limits of the limit switches are preset at about three turns of the roller.

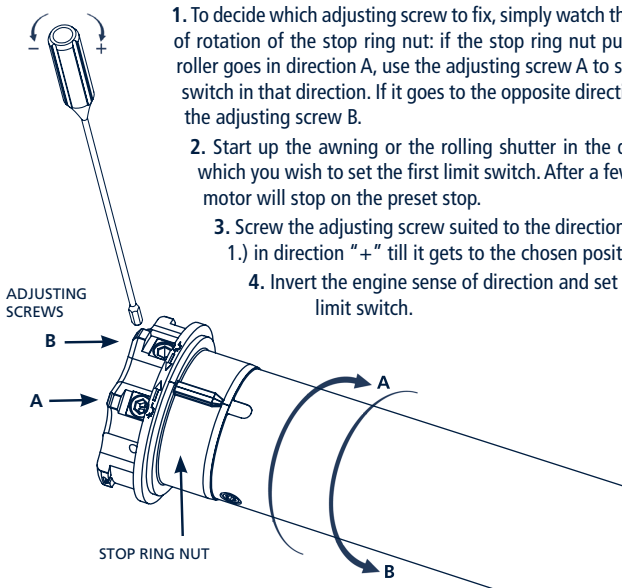

1. To decide which adjusting screw to fix, simply watch the direction of rotation of the stop ring nut: if the stop ring nut pulled by the roller goes in direction A, use the adjusting screw A to set the limit switch in that direction. If it goes to the opposite direction (B), use the adjusting screw B.
2. Start up the awning or the rolling shutter in the direction in which you wish to set the first limit switch. After a few turns the motor will stop on the preset stop.
3. Screw the adjusting screw suited to the direction (see point 1.) in direction "+" till it gets to the chosen position.
4. Invert the engine sense of direction and set the second limit switch.

EU DECLARATION OF CONFORMITY

CHERUBINI S.p.A. declares that the product is in conformity with the relevant Union harmonisation legislation:

Directive 2014/35/EU

Directive 2014/30/EU

Directive 2011/65/EU

The full text of the EU declaration of conformity is available upon request at the following website: www.cherubini.it.





CHERUBINI S.p.A.

Via Adige 55
25081 Bedizzole (BS) - Italy
Tel. +39 030 6872.039
info@cherubini.it | www.cherubini.it

CHERUBINI Iberia S.L.

Avda. Unión Europea 11-H
Apdo. 283 - P. I. El Castillo
03630 Sax Alicante - Spain
Tel. +34 (0) 966 967 504 | Fax +34 (0) 966 967 505
info@cherubini.es | www.cherubini.es

CHERUBINI France SAS

ZI Du Mas Barbet
165 Impasse Ampère
30600 Vauvert - France
Tél. +33 (0) 466 77 88 58
info@cherubini.fr | www.cherubini.fr

CHERUBINI Deutschland GmbH

Rotter Viehtrift 4A - 53842 Troisdorf - Deutschland
Tel. +49 (0) 224 126 699 74 | Fax +49 (0) 224 126 699 73
info@cherubini-group.de | www.cherubini-group.de